

*Air Movement and Control
Association International, Inc.*

Certifies that

Ventech Systems Pvt. Ltd.

*Having satisfied the membership requirements, has been granted membership in the
Air Movement and Control Association International, Inc.*

*Member Since
February, 2014*

H. Meard
AMCA International President



Executive Director



Testing of 'Ventech' Fan at AMCA accredited laboratory in Malaysia

RANGE OF PRODUCTS

- Axial Flow Fans • Centrifugal Blowers • Kitchen Scrubbers • Ventilation Units
- Air Cooling Units • Dust Collectors • Rotary Airlocks • Air Handling System Accessories

RANGE OF SYSTEMS

- Pressurisation & Ventilation • Evaporative Air Cooling • Dust Extraction & Collection
- Fume Extraction & Collection • Fresh Air Supply & Exhaust • Kitchen Ventilation
- Pneumatic Conveying • Air Conditioning



VENTECH SYSTEMS PVT. LTD.

(An ISO 9001 : 2015 Certified Company)
(Recipient of Bhartiya Udyog Ratna Award)
(Authorized Channel Partners of Hitachi & LG)



Corporate Office: 511, Vikas Deep, Laxmi Nagar District Centre, Vikas Marg, New Delhi – 110 092 (India)
Phone: + 91 – 11 – 22454054 , 22454059 **Mobile:** + 91 97110 03363
Telefax: + 91 – 11 – 42448063 • **E-mail:** info@ventechsystems.com, sales@ventechsystems.com

Branch Office: 410, Angel Mega Mall, CK-1, Kaushambi, Ghaziabad
Works: Ghaziabad & Delhi

Regional Representatives: Lucknow, Raipur, Ahmedabad, Hyderabad, Karnal
Overseas Representatives: Canada, Singapore, South Africa



VENTECH CLASSIC AIRFOIL AXIAL FAMILY

AXIAL FLOW FAN (RAV VAR Series)

www.ventechsystems.com

All Rights reserved. No part of this publication may be copied or published by means of printing, photocopying, microfilm or otherwise without prior written consent of Ventech Systems Pvt. Ltd. This restriction also applies to the corresponding drawings and diagrams.

In view of our constant endeavour to improve the quality of our products & systems , we reserve the right to alter the specifications without prior notice. We reserve the right to modify the specifications in accordance with improved designs. Although every effort will be made to maintain accuracy in the data given, the figures must be taken as approximate and in no way binding . Contact us for more information.

PRODUCT DESCRIPTION

VENTECH SYSTEMS PVT. LTD., a pioneer and renowned leader in Air Handling Technology offers a wide range of Axial Flow Fans suitable for Industrial Ventilation, Air Conditioning, Dust Extraction and Fume Extraction Systems.

AMCA an International Authority on Air System Components has certified Direct Driven Fans of RAV-VAR (DD Series) for Sound and Air Performance as per AMCA Standards 300 AND 210 Respectively.

TYPICAL APPLICATIONS

- Air Conditioning
- Humidification
- Smoke / Stale Air Exhaust
- Spray booth exhaust
- Building ventilation
- Fume Exhaust
- Oven exhaust
- Kitchen exhaust

VENTECH's engineered axial fans comprise of various blade and hub configurations, based on each application's performance requirements. The key to success is our innovative design that allows us to create a very wide range of axial fans tailor-made for specific needs.

High-strength, Die-cast Aluminium hubs are combined with our high-efficiency blade profiles of variable pitch and fixed pitch type. Machining, assembly, trimming and balancing are performed using the best processes and ISO 9001:2015 certified conditions to create the perfect axial fan to match particular needs of a customer.

- ⊗ Airflow Direction: Air flowing from motor to impeller are fitted as standard. Air flowing from impeller to motor can be supplied on request.
- ⊗ Static Pressure: upto 100 mm.wg. in single stage. Higher pressures are possible on multi-stage versions, contra-rotating.
- ⊗ Comprehensive choice of diameters: Ranges from 250 mm to 1600 mm (10" to 64").
- ⊗ Capable of handling flow rates up to 1,50,000 CMH.
- ⊗ Inspection Door / View Port is provided as standard.
- ⊗ Suitable for Outdoor and Indoor Applications.

At VENTECH, we build fans for every possible ventilation need. Choose from one of the most comprehensive and widest range of axial fan family manufactured by VENTECH, one of the Pioneers and acknowledged leader in Air Handling Technology.

FANS FOR ALL POSSIBLE REQUIREMENTS



TECHNICAL SPECIFICATIONS

CONSTRUCTIONAL FEATURES AND OPTIONS

Direct Driven Axial Fan



Belt Driven Axial Fan

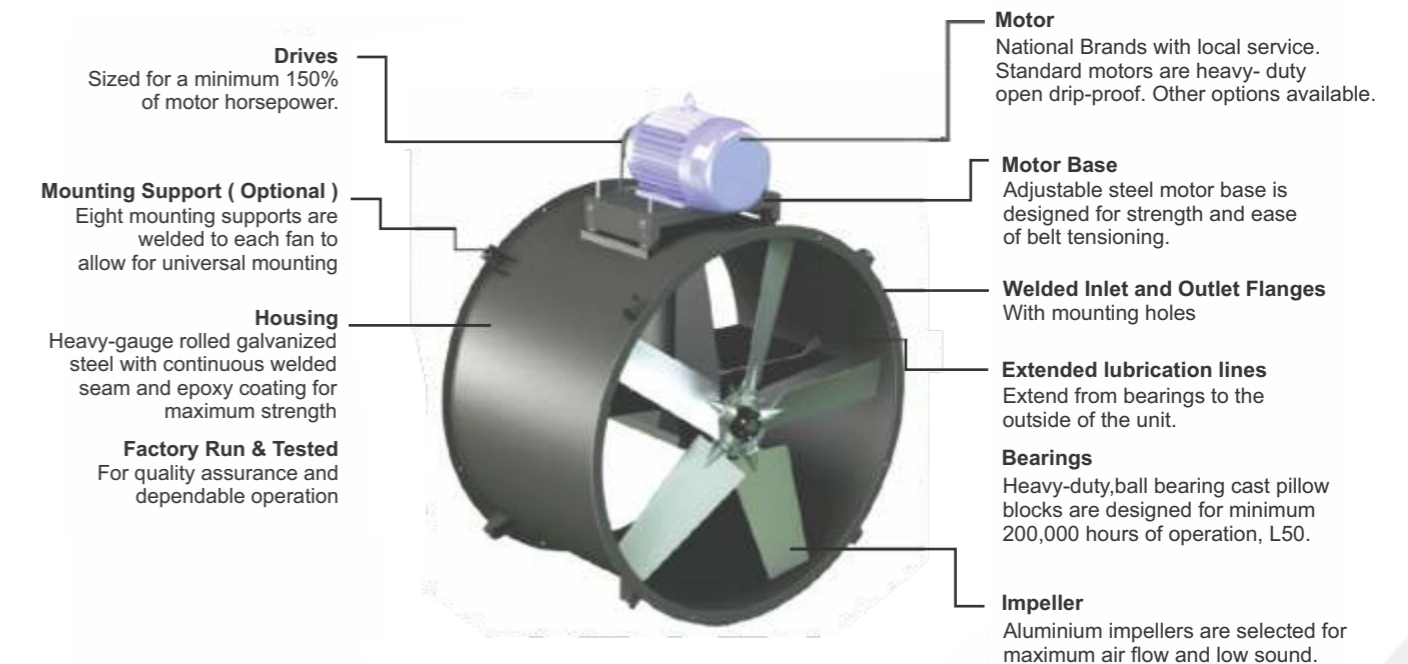

- ⊗ Casing is constructed of heavy gauge MS Sheet (as per IS-1079/2062), continuously welded steel casing to prevent air leakage.
- ⊗ Inlet and outlet flanges are welded properly to the fan casing sheet to ensure concentricity and alignment. Flanges have pre punched mounted holes for easy installation.
- ⊗ Motor base plate fabricated of heavy steel plates and welded to the interior of fan casing to prevent vibration or pulsation.

TECHNICAL SPECIFICATIONS

IMPELLERS

Airfoil Impellers - Exceptional performance with high efficiency

Our airfoil profile provides uniform, high-volume airflow with low power consumption for optimum efficiency. The airfoil's twisted blade creates a broad operating range, making it suitable for everything from the most demanding applications in the field of ventilation.

Some of the outstanding features are :-

- ☉ Suitable for operating in Temperature range from -60°C to +245°C and High temperature tested at 250°C for maximum 2 hours and at 300°C for maximum 1 hour.
- ☉ Adjustable pitch angles for exact performance matching. Fixed pitch angle configuration is also offered.
- ☉ Well designed pressure die cast Aluminium blades, EN AC-AI Si12Cu1(Fe) (AL).
- ☉ Designed to be used with taper-lock bushings for superior holding power on shaft.
- ☉ Aluminium components are natural finish as standard.
- ☉

MOTORS

- ☉ Standard Motors for running Normal fans are suitable for operation on 415 volts $\pm 10\%$, 50 Hz $\pm 5\%$, 3 Phase Power Supply, conforming to IS:325/1996 & IS 12615:2011.
- ☉ Motor is closely matched to the fan load and provided at the voltage, phase, hertz and enclosure as requested by client.
- ☉ Energy efficient TEFC motors used EFF1, EFF2, IE2, IE3 etc.
- ☉ Axial Fans are available in single phase version also.

FINISH & COATING

- ☉ Depending on application, entire fan assembly (excluding shaft and impeller) can be hot-dipped galvanized.
- ☉ Standard fans are finished with synthetic enamel paint after application of rust-preventive primer.
- ☉ On request, fans can be supplied with casing made of stainless steel or zinc sprayed MS sheet.
- ☉ Epoxy / chlorinated rubber paint may also be provided.

FACTORY RUN TEST

- ☉ Impellers are statically and dynamically balanced on microprocessor controlled machine as per IS-1940 balanced quality grade G-6.3 and can also be fine balanced to G 2.5.
- ☉ All fans are completely assembled and subjected to our Factory Acceptance Test prior to shipment.

QUALITY ASSURANCE

- ☉ Air performance and static pressure data of AMCA certified Tube Axial Fans of RAVVAR Series is based on tests conducted in AMCA's state-of-the-art airflow and acoustics AMCA Certified Laboratory in Malaysia/Singapore. We guarantee to deliver rated published performance levels of certified fans.
- ☉ Axial Flow Fans can also be tested in accordance with IS-3588-1991 standards on customer's request.
- ☉ Test procedures are in accordance with relevant AMCA standards.

DIRECT DRIVEN AXIAL FAN (LONG / SHORT CASED)

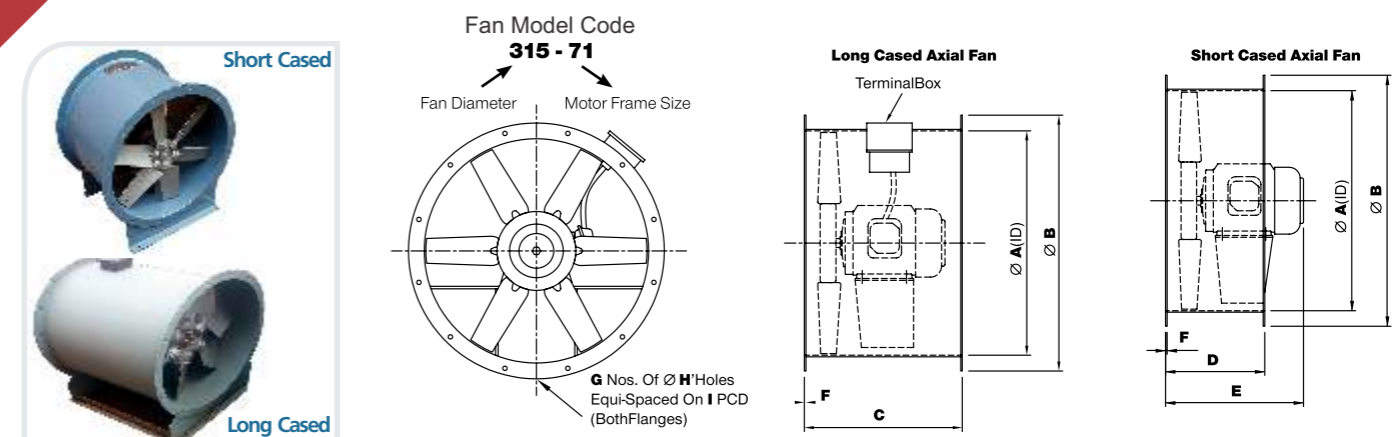

Fan Model Code	A	B	C	D	E	F	G	H	I
RAVVAR 350-71	350	435	300	180	300	6.0	12	11.5	396
RAVVAR 400-71	400	486	350	220	300	6.0	12	11.5	446
RAVVAR 400-80	400	486	350	220	335	6.0	12	11.5	446
RAVVAR 400-90S	400	486	350	220	360	6.0	12	11.5	446
RAVVAR 400-90L	400	486	350	220	385	6.0	12	11.5	446
RAVVAR 450-71	450	535	350	220	300	6.0	12	11.5	495
RAVVAR 450-80	450	535	350	220	335	6.0	12	11.5	495
RAVVAR 450-90S	450	535	350	220	360	6.0	12	11.5	495
RAVVAR 450-90L	450	535	350	220	385	6.0	12	11.5	495
RAVVAR 500-71	500	586	400	220	300	6.0	12	11.5	546
RAVVAR 500-80	500	586	400	220	335	6.0	12	11.5	546
RAVVAR 500-90S	500	586	400	220	360	6.0	12	11.5	546
RAVVAR 500-90L	500	586	400	220	385	6.0	12	11.5	546
RAVVAR 560-71	560	646	450	220	300	6.0	12	11.5	606
RAVVAR 560-80	560	646	450	220	335	6.0	12	11.5	606
RAVVAR 560-90S	560	646	450	220	360	6.0	12	11.5	606
RAVVAR 560-90L	560	646	450	220	385	6.0	12	11.5	606
RAVVAR 560-100L	560	646	450	250	430	6.0	12	11.5	606
RAVVAR 560-112M	560	646	450	250	450	6.0	12	11.5	606
RAVVAR 630-71	630	716	450	250	300	6.0	16	11.5	676
RAVVAR 630-80	630	716	450	250	335	6.0	16	11.5	676
RAVVAR 630-90S	630	716	450	250	360	6.0	16	11.5	676
RAVVAR 630-90L	630	716	450	250	385	6.0	16	11.5	676
RAVVAR 630-100L	630	716	450	250	430	6.0	16	11.5	676
RAVVAR 630-112M	630	716	450	250	450	6.0	16	11.5	676
RAVVAR 710-80	710	796	590	250	335	6.0	16	11.5	756
RAVVAR 710-90S	710	796	590	250	360	6.0	16	11.5	756
RAVVAR 710-90L	710	796	590	250	385	6.0	16	11.5	756
RAVVAR 710-100L	710	796	590	250	430	6.0	16	11.5	756
RAVVAR 710-112M	710	796	590	250	450	6.0	16	11.5	756
RAVVAR 710-132S	710	796	590	300	525	6.0	16	11.5	756
RAVVAR 800-80	800	886	600	250	335	6.0	20	11.5	846
RAVVAR 800-90S	800	886	600	250	360	6.0	20	11.5	846
RAVVAR 800-90L	800	886	600	250	385	6.0	20	11.5	846
RAVVAR 800-100L	800	886	600	250	430	6.0	20	11.5	846
RAVVAR 800-112M	800	886	600	250	450	6.0	20	11.5	846
RAVVAR 800-132S	800	886	600	300	525	6.0	20	11.5	846
RAVVAR 800-132M	800	886	600	300	565	6.0	20	11.5	846
RAVVAR 900-90S	900	986	730	250	360	6.0	20	11.5	946
RAVVAR 900-90L	900	986	730	250	385	6.0	20	11.5	946

Note : ☉ Length of casing shall vary according to motor frame size and can be modified to suit site constraints.

DIRECT DRIVEN AXIAL FAN (LONG / SHORT CASED)

FLANGE MOUNTING HOLES

Fan Diameters

350, 400, 450, 500, 560

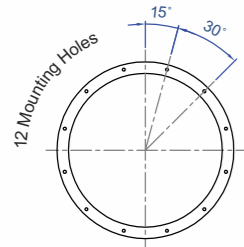

Fan Diameters

630, 710

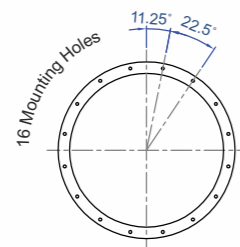

Fan Diameters

800, 900, 1000, 1120

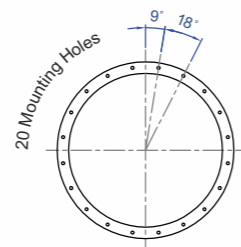

Fan Diameters

1250, 1400, 1600

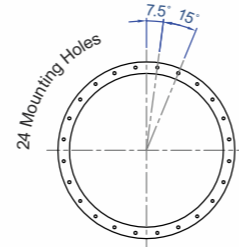

Fan Model Code	A	B	C	D	E	F	G	H	I
RAVVAR 900-100L	900	986	730	250	430	6.0	20	11.5	946
RAVVAR 900-112M	900	986	730	250	450	6.0	20	11.5	946
RAVVAR 900-132S	900	986	730	300	525	6.0	20	11.5	946
RAVVAR 900-132M	900	986	730	300	565	6.0	20	11.5	946
RAVVAR 1000-100L	1000	1088	760	300	430	6.0	20	11.5	1046
RAVVAR 1000-112M	1000	1088	760	300	450	6.0	20	11.5	1046
1RAVVAR 000-132S	1000	1088	760	300	525	6.0	20	11.5	1046
RAVVAR 1000-132M	1000	1088	760	300	565	6.0	20	11.5	1046
RAVVAR 1000-160M	1000	1088	760	420	660	6.0	20	11.5	1046
RAVVAR 1000-160L	1000	1088	760	420	700	6.0	20	11.5	1046
RAVVAR 1120-132S	1120	1206	790	300	525	8.0	20	11.5	1166
RAVVAR 1120-132M	1120	1206	790	300	565	8.0	20	11.5	1166
RAVVAR 1120-160M	1120	1206	790	420	660	8.0	20	11.5	1166
RAVVAR 1120-160L	1120	1206	790	420	700	8.0	20	11.5	1166
RAVVAR 1250-132S	1250	1358	1000	300	525	8.0	24	14	1306
RAVVAR 1250-132M	1250	1358	1000	300	565	8.0	24	14	1306
RAVVAR 1250-160M	1250	1358	1000	420	660	8.0	24	14	1306
RAVVAR 1250-160L	1250	1358	1000	420	700	8.0	24	14	1306
RAVVAR 1250-180M	1250	1358	1000	500	720	8.0	24	14	1306
RAVVAR 1250-180L	1250	1358	1000	500	760	8.0	24	14	1306
RAVVAR 1250-200L	1250	1358	1000	550	825	8.0	24	14	1306
RAVVAR 1250-225S	1250	1358	1000	590	870	8.0	24	14	1306
RAVVAR 1250-225M	1250	1358	1000	590	895	8.0	24	14	1306
RAVVAR 1400-180M	1400	1508	1200	500	720	8.0	24	14	1456
RAVVAR 1400-180L	1400	1508	1200	500	760	8.0	24	14	1456
RAVVAR 1400-200L	1400	1508	1200	550	825	8.0	24	14	1456
RAVVAR 1400-225S	1400	1508	1200	590	870	8.0	24	14	1456
RAVVAR 1400-225M	1400	1508	1200	590	895	8.0	24	14	1456
RAVVAR 1400-250S	1400	1508	1200	590	935	8.0	24	14	1456
RAVVAR 1400-250M	1400	1508	1200	590	980	8.0	24	14	1456
RAVVAR 1400-280S	1400	1508	1200	690	1070	8.0	24	14	1456
RAVVAR 1400-280M	1400	1508	1200	690	1120	8.0	24	14	1456
RAVVAR 1600-180M	1600	1708	1200	500	720	8.0	24	14	1656
RAVVAR 1600-180L	1600	1708	1200	500	760	8.0	24	14	1656
RAVVAR 1600-200L	1600	1708	1200	550	825	8.0	24	14	1656
RAVVAR 1600-225S	1600	1708	1200	590	870	8.0	24	14	1656
RAVVAR 1600-225M	1600	1708	1200	590	895	8.0	24	14	1656
RAVVAR 1600-250S	1600	1708	1200	590	935	8.0	24	14	1656
RAVVAR 1600-250M	1600	1708	1200	590	980	8.0	24	14	1656
RAVVAR 1600-280S	1600	1708	1200	690	1070	8.0	24	14	1656
RAVVAR 1600-280M	1600	1708	1200	690	1120	8.0	24	14	1656

Note : 1800 mm diameter fan is also available on request.

BELT DRIVEN AXIAL FANS (LONG CASING ONLY)

RAV VAR-BD SERIES

VENTECH Belt driven Fans are driven by belt and pulley arrangement. The motor is located outside the air stream. VENTECH belt driven fans are ideal for moisture laden or dust laden or where system is required to exhaust hot air.

In this arrangement, the fan shaft and its bearings are mounted in a bearing housing fastened by three support arms to the surrounding casing.



Fan Model Code Interpretation

Fan Model Code

315 - 71

Fan Diameter Motor Frame Size

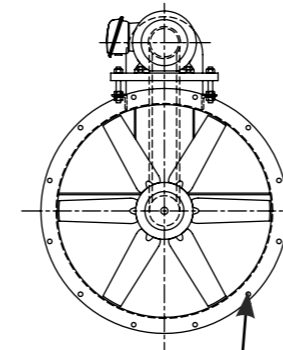

'E' Nos. of \varnothing 'F' Holes Equi-Spaced On 'G' PCD (Both Flanges)

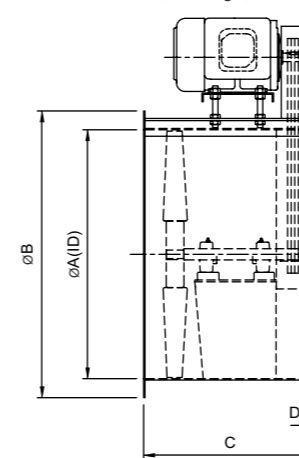

Fan Model Code	A	B	C	D	E	F	G
RAVVAR 350-71	350	435	400	6.0	12	11.5	396
RAVVAR 350-80	350	435	400	6.0	12	11.5	396
RAVVAR 400-71	400	486	450	6.0	12	11.5	446
RAVVAR 400-80	400	486	450	6.0	12	11.5	446
RAVVAR 400-90S	400	486	450	6.0	12	11.5	446
RAVVAR 400-90L	400	486	450	6.0	12	11.5	446
RAVVAR 450-71	450	536	450	6.0	12	11.5	495
RAVVAR 450-80	450	536	450	6.0	12	11.5	495
RAVVAR 450-90S	450	536	450	6.0	12	11.5	495
RAVVAR 450-90L	450	536	450	6.0	12	11.5	495
RAVVAR 500-71	500	586	500	6.0	12	11.5	546
RAVVAR 500-80	500	586	500	6.0	12	11.5	546
RAVVAR 500-90S	500	586	500	6.0	12	11.5	546
RAVVAR 500-90L	500	586	500	6.0	12	11.5	546
RAVVAR 500-100L	500	586	500	6.0	12	11.5	546
RAVVAR 560-71	560	646	500	6.0	12	11.5	606
RAVVAR 560-80	560	646	500	6.0	12	11.5	606
RAVVAR 560-90S	560	646	500	6.0	12	11.5	606
RAVVAR 560-90L	560	646	500	6.0	12	11.5	606
RAVVAR 560-90L	560	646	500	6.0	12	11.5	606
RAVVAR 560-100L	560	646	500	6.0	12	11.5	606
RAVVAR 560-112M	560	646	500	6.0	12	11.5	606
RAVVAR 630-71	630	716	500	6.0	16	11.5	676
6RAVVAR 30-80	630	716	500	6.0	16	11.5	676
RAVVAR 630-90S	630	716	500	6.0	16	11.5	676
RAVVAR 630-90L	630	716	500	6.0	16	11.5	676
RAVVAR 630-100L	630	716	500	6.0	16	11.5	676
RAVVAR 630-112M	630	716	500	6.0	16	11.5	676
RAVVAR 710-80	710	796	500	6.0	16	11.5	756
RAVVAR 710-90S	710	796	500	6.0	16	11.5	756
RAVVAR 710-90L	710	796	500	6.0	16	11.5	756
RAVVAR 710-100L	710	796	500	6.0	16	11.5	756
RAVVAR 710-112M	710	796	500	6.0	16	11.5	756
RAVVAR 800-80	800	886	550	6.0	20	11.5	846
RAVVAR 800-90S	800	886	550	6.0	20	11.5	846
RAVVAR 800-90L	800	886	550	6.0	20	11.5	846
RAVVAR 800-100L	800	886	550	6.0	20	11.5	846
RAVVAR 800-112M	800	886	550	6.0	20	11.5	846

BELT DRIVEN AXIAL FANS (LONG CASING ONLY)

FLANGE MOUNTING HOLES

Fan Diameters

350, 400, 450, 500, 560

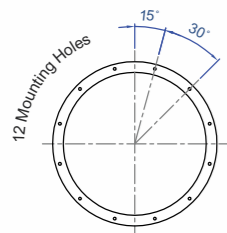

Fan Diameters

630, 710

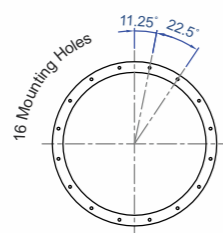

Fan Diameters

800, 900, 1000, 1120

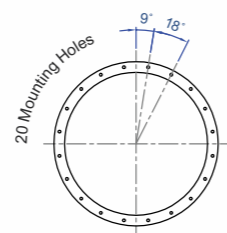

Fan Diameters

1400

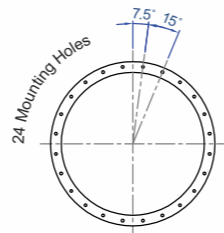

Fan Model Code	A	B	C	D	E	F	G
RAVVAR 800-132S	800	886	550	6.0	20	11.5	846
RAVVAR 800-132M	800	886	550	6.0	20	11.5	846
RAVVAR 900-90S	900	986	550	6.0	20	11.5	946
RAVVAR 900-90L	900	986	550	6.0	20	11.5	946
RAVVAR 900-100L	900	986	550	6.0	20	11.5	946
RAVVAR 900-112M	900	986	550	6.0	20	11.5	946
RAVVAR 900-132S	900	986	550	6.0	20	11.5	946
RAVVAR 900-132M	900	986	550	6.0	20	11.5	946
RAVVAR 1000-90S	1000	1088	800	6.0	20	11.5	1046
RAVVAR 1000-90L	1000	1088	800	6.0	20	11.5	1046
RAVVAR 1000-100L	1000	1088	800	6.0	20	11.5	1046
RAVVAR 1000-112M	1000	1088	800	6.0	20	11.5	1046
RAVVAR 1000-132S	1000	1088	800	6.0	20	11.5	1046
RAVVAR 1000-132M	1000	1088	800	6.0	20	11.5	1046
RAVVAR 1000-160M	1000	1088	800	6.0	20	11.5	1046
RAVVAR 1000-160L	1000	1088	800	6.0	20	11.5	1046
RAVVAR 1120-132S	1120	1206	800	8.0	20	11.5	1166
RAVVAR 1120-132M	1120	1206	800	8.0	20	11.5	1166
RAVVAR 1120-160M	1120	1206	800	8.0	20	11.5	1166
RAVVAR 1120-160L	1120	1206	800	8.0	20	11.5	1166
RAVVAR 1120-180M	1120	1206	800	8.0	20	11.5	1166
RAVVAR 1120-180L	1120	1206	800	8.0	20	11.5	1166
RAVVAR 1120-200L	1120	1206	800	8.0	20	11.5	1166
RAVVAR 1250-132S	1250	1358	1000	8.0	20	14	1306
RAVVAR 1250-132M	1250	1358	1000	8.0	20	14	1306
RAVVAR 1250-160M	1250	1358	1000	8.0	20	14	1306
RAVVAR 1250-160L	1250	1358	1000	8.0	20	14	1306
RAVVAR 1250-180M	1250	1358	1000	8.0	20	14	1306
RAVVAR 1250-180L	1250	1358	1000	8.0	20	14	1306
RAVVAR 1250-200L	1250	1358	1000	8.0	20	14	1306
RAVVAR 1250-225S	1250	1358	1000	8.0	20	14	1306
RAVVAR 1250-225M	1250	1358	1000	8.0	20	14	1306
RAVVAR 1250-250S	1250	1358	1000	8.0	20	14	1306
RAVVAR 1250-250M	1250	1358	1000	8.0	20	14	1306

Note : • Dimensions / details of larger diameters available
• Length of casing shall vary according to motor frame size and can be modified to suit site constraints.

SMOKE EXTRACTION FANS (RAV VAR SE- Series)

VENTECH offers you a large range of smoke extraction solutions by means of being our Smoke Extraction Fans which have been successfully tried and tested for smoke extraction in case of fire.

FEATURES

- Comprehensive choice of diameters: Ranges from 250 mm to 1600 mm (10" to 64").
- Special Terminal Box with approximately 1 m lead is provided as standard.
- Capable of handling flow rates up to 1,50,000 CMH.
- Static Pressures of up to 100 mm.wg. in single stage.
- Direct Driven.

The Smoke-Extraction Fans operate as so-called "Dual-Function Fans":

- Reducing secondary damage due to thermal by-products & hot gases.
- Supporting fire fighting by creating a smoke-free zone.
- Reducing the heat stress of components during a fire.
- Normal operation (no instance of fire).
- Fault operation (in case of fire).
- Protecting devices & equipment.



APPLICATIONS:

Typical application examples include:

- Single & multi-storey shopping centres
- Tunnels
- Theatres
- Industrial buildings & warehouses
- Building complexes & atriums
- Basements

SPECIAL FEATURES OF MOTORS FOR SMOKE EXTRACTION APPLICATIONS

VENTECH fans use Fire rated / Smoke extraction Motors suitable for running in the most hazardous environments i.e Ventech Fans are fire rated for:

- 250 deg. C for 2 hours continuous operation.
- 300 deg. C for 2 hours continuous operation.
- Motors are VFD Compatible.
- Class of Insulation Available: 'H'

SUPPLY VOLTAGE AND FREQUENCY

Voltage	200-690 V ± 10%
Frequency	50/60 Hz ± 5%
Standard motors are wound for 3 phase, 415 V, 50 Hz supply condition	
Specification	BS EN:12101-3
Construction	Terminal Box can be rotated 360 deg. In steps of 90 deg.
Performance	IE1 / IE2 compatible with VFD Dual Speed option available.

MULTIPLE OPTIONS, ONE SOLUTION

Following special application fans are also offered depending on application and end use.

As all fans are incorporated with our high performance impellers, you can be assured of superior and reliable ventilation regardless of fan type, every time.

VENTILATION FOR HAZARDOUS APPLICATIONS

Explosion Proof Fans (RAV VAR – EP Series)

- ☉ Fitted with explosion proof / flame proof electric motors to meet exact hazardous location standards.
- ☉ Specially constructed for safe handling of explosive or flammable particles, fumes or vapors.
- ☉ Non-ferrous wheel and non-ferrous ring are provided.
- ☉ Available in different sizes starting from 300 mm diameter.



RELIABLE VENTILATION FOR HOSTILE ENVIRONMENT

VENTECH Bifurcated Fans (RAV VAR – BF Series)

- ☉ These fans are used to handle hazardous air, where motors are kept outside the air stream.
- ☉ Suitable for kitchen use or other hostile and highly contaminated environments.
- ☉ Available in different sizes starting from 500 mm diameter.
- ☉ Suitable where it is required to handle hot air / gas.
- ☉ Air working temperatures of 150°C - 250°C.



VENTECH Roof Extractor Units (RAV VAR – RE Series)

- ☉ These Roof Extractors incorporate a heavy duty galvanized steel stack cap with butterfly dampers to discharge air upward and prevent recirculation into the building.
- ☉ Mild Steel Cowling: choice of plain mild steel cowl or cowl with adjustable damper for marine & industrial applications.
- ☉ FRP Cowling: for cost effective non-hazardous industrial or commercial applications.
- ☉ These units are used on the roof to extract and exhaust contaminated air.
- ☉ Range: 300mm to 1600 mm diameter.



VENTECH Propeller Exhaust Fans (VPF Series)

- ☉ Totally enclosed continuously rated motor
- Every Ventech Propeller Exhaust Fan features a capacitor start and run type motor, continuously rated, totally enclosed and ruggedly built.
- ☉ Dynamically balanced sheet metal fabricated impeller.
- Since both hub and impeller are dynamically balanced, frames and arms mounted on rubber bushings, vibrations are virtually eliminated.



MULTIPLE OPTIONS, ONE SOLUTION

SQUARE PLATE AXIAL FAN UNITS FOR WALL MOUNTING

Wall Mounted square plate axial flow fans (RAVVAR -WM Series)

These fans are an efficient alternative to the ducted axial fan where installation is a constraint. Suitable to be run using single / three phase motors.



☉ RAVVAR- WM - DD Series:

This arrangement is intended exclusively for use where the motor can be placed in the air current and where no change in speed is required. This is suitable for wall mounting.

☉ RAVVAR - WM - BD Series:

This arrangement is used for blowing hot air or gas that the motor must be mounted outside the air current. The wall frame has a streamlined inlet. The impeller is attached to one end of the shaft supported by two ball bearings in one common housing which is supported on a bracket fitted to the wall frame. A pulley can be attached to the other free end of the shaft.

- ☉ Useful for general industrial and commercial ventilation.
- ☉ Available in either exhaust or supply configurations.
- ☉ Square plates for wall mounting.

ADAPTABLE & PORTABLE VENTILATION

Industrial Man coolers (VTM, VPM & VCM Series)

- ☉ Ventech Industrial Mancoolers are designed for delivering powerful air stream for spot cooling for men, machines and material. These units are extensively used for cooling, drying & heat removal applications. Our Mancoolers have special features of swivelling and tilting arrangement.
- ☉ Ventech Industrial Mancoolers aid in the dissipation of body heat through a higher evaporation rate, assisting to prevent heat exhaustion and increase personal safety.
- ☉ Particularly effective where a clean healthy environment must be maintained for the safety of workers.
- ☉ Column Mounted with tilting and swivelling arrangement (VCM Series).
- ☉ Provide direct draft of air on MEN, MATERIAL and MACHINES.
- ☉ Range : 500 to 1000 mm impeller diameter.
- ☉ Available in 3 Types.
 - Tubular Mounted. (VTM Series)
 - Pedestal Mounted. (VPM Series)
 - Column mounted with tilting & Swivelling arrangement. (VCM Series)



OPTIONAL ACCESSORIES

FOLLOWING EXTENSIVE RANGE OF ACCESSORIES ARE ALSO AVAILABLE.

Gravity Louvered Shutters

- ☛ Suitable designed shutters work on the principle of gravity i.e they open when the fan is in running mode and shut automatically when fan is not in running mode.



Exhaust Cowl and Bird Screen

- ☛ Offered to Prevent ingress of foreign particles inside the axial fans when mounted on walls.



Filter/Filter Frame with adapter cone

- ☛ Normally used in the case of fresh air ventilation to trap outside dust particles to the maximum extent possible.



Dampers

- ☛ Offered to regulate air flow.
- ☛ Can be fabricated in different materials of construction.



DOL and Star Delta Starters

- ☛ Starters of reputed make can be provided on request .



Acoustic Silencers

- ☛ Silencers can be added to both the fan inlet and outlet for the most critical noise applications.
- ☛ Silencers are designed to reduce fan noise with minimal resistance to airflow.

Vibration Isolators

- ☛ Rubber-in-shear and spring type isolators are available for floor or ceiling mounting.



Protective Screens

- ☛ Recommended for use when no duct work is attached to the inlet and/or outlet.
- ☛ Screens are removable for routine inspection and cleaning of impeller.
- ☛ Offered to protect personnel from moving parts.

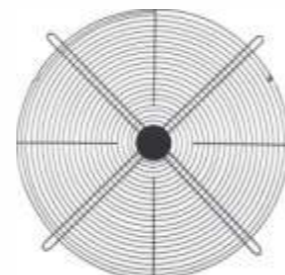

OPTIONAL ACCESSORIES

Flexible Collar with Matching Flanges

- ☛ Provides flexible interconnection and isolation of vibration with any matched interface.

A	B	C	D
350	435	100	150
400	486	100	150
500	586	100	150
560	646	100	150
630	716	150	200
710	790	150	200
800	886	150	200
900	986	150	200
1000	1088	150	200
1120	1206	150	200
1250	1358	150	200
1400	1508	150	200
1600	1708	150	200

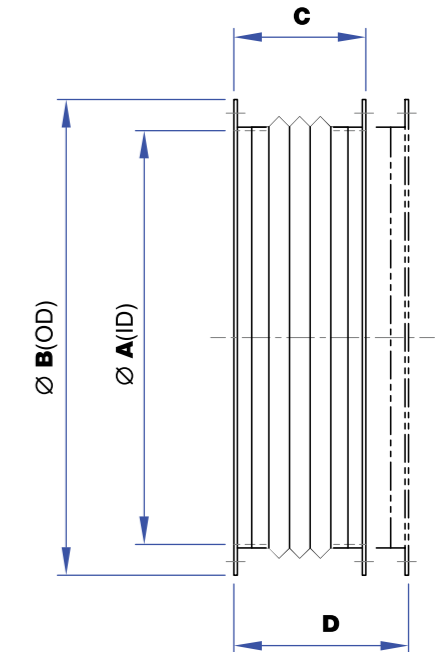

Inlet Cones

- ☛ Recommended to minimize losses for installations where inlet of the fan is not attached to a ducted system.
- ☛ Inlet and outlet cones offer a round-to-round transition from the fan inlet and/or outlet to the specific duct diameter of the system.

A	B	C	D	E
350	435	60	400	6.0
400	486	70	510	6.0
500	586	90	640	6.0
560	646	100	715	6.0
630	716	110	800	6.0
710	796	125	890	6.0
800	886	135	995	6.0
900	986	150	1110	6.0
1000	1088	165	1230	6.0
1120	1206	185	1375	8.0
1250	1358	205	1525	8.0
1400	1508	230	1710	8.0
1600	1708	265	1960	8.0

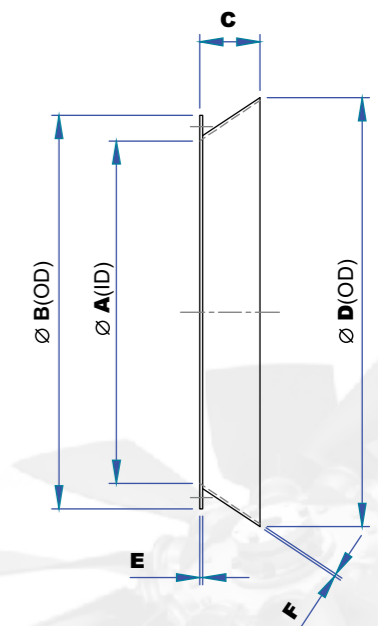

OPTIONAL ACCESSORIES

Matching Flanges

⊗ Rolled angle / flat rings that match the fan inlet and outlet flanges to provide easy attachment for slip duct connections.

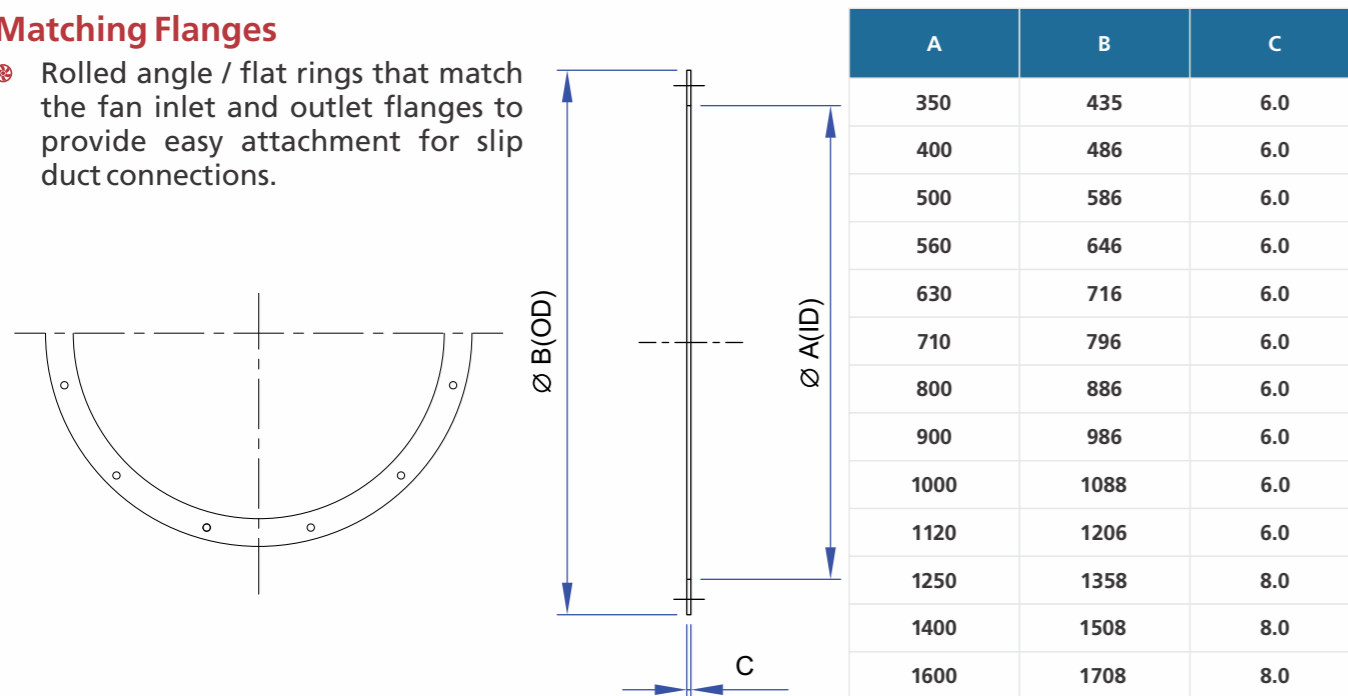

Mounting Brackets

⊗ Mounting brackets are bolted to the inlet and outlet of the fan.
 ⊗ Available for ceiling hung or floor mount configurations.

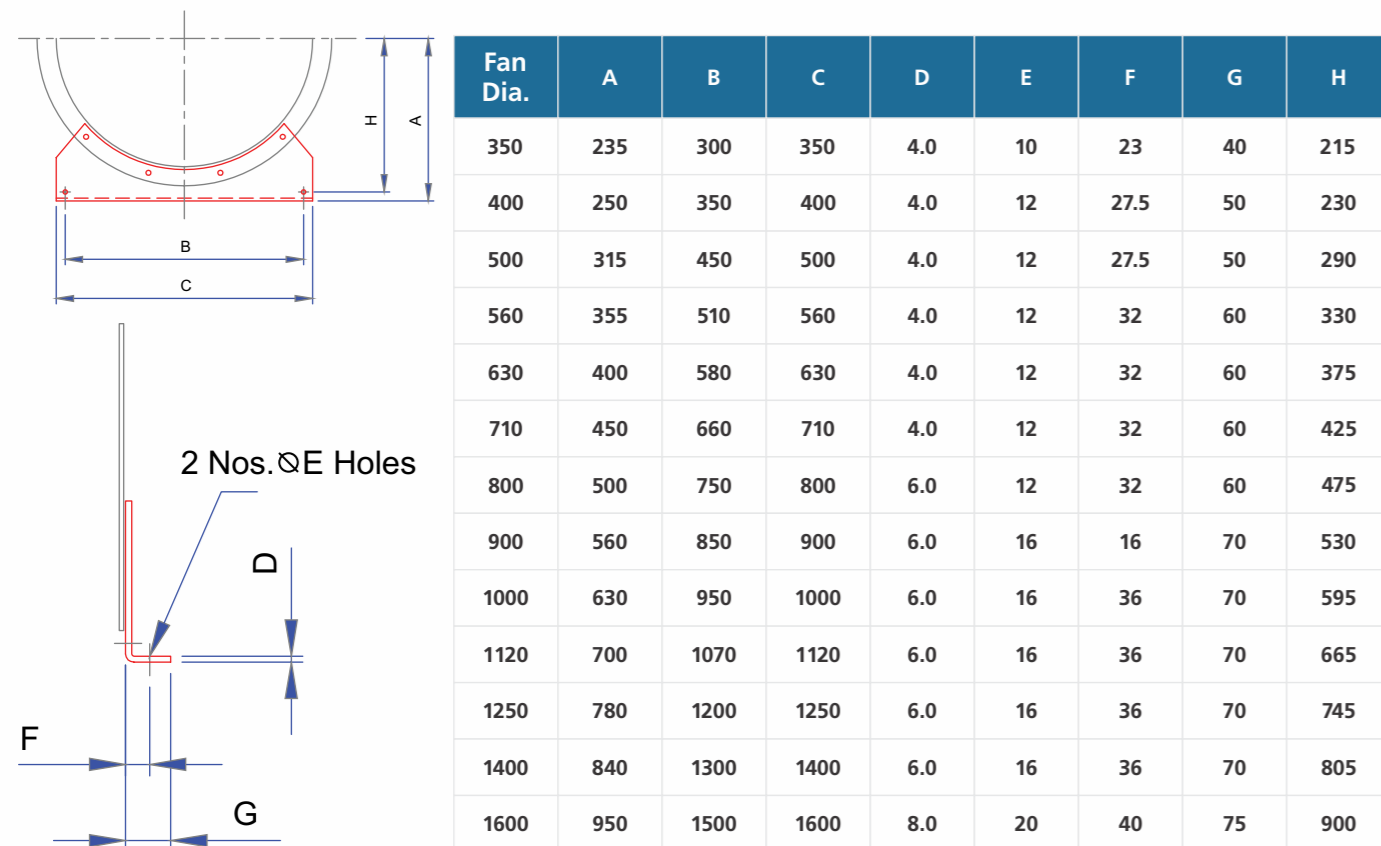

MOUNTING TYPES

FOOT MOUNTED - HORIZONTAL

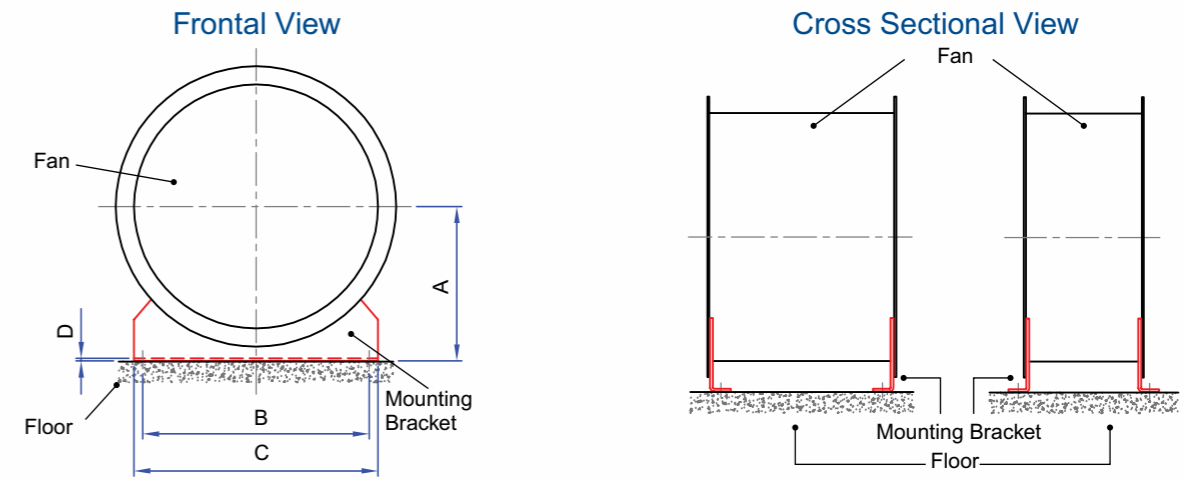

CEILING MOUNTED - HORIZONTAL

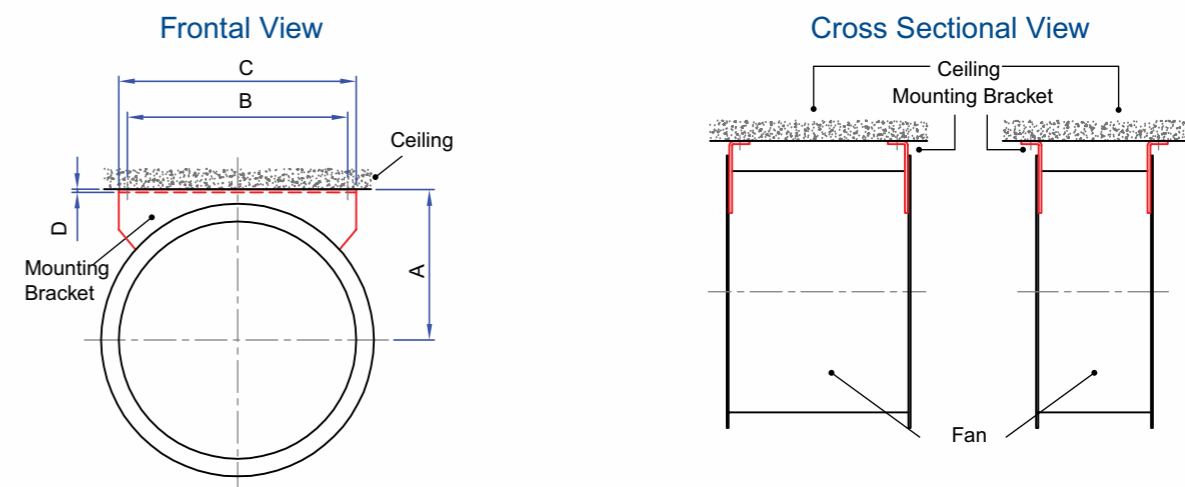

RIGID MOUNTED - VERTICAL

